

features

- SMD platinum thin film thermal sensors
- T.C.R. is in accordance to JIS-DIN standards IEC
- Suitable for temperature control in various industrial equipment
- Suitable for both flow and reflow solderings
- Products meet EU RoHS requirements

dimensions and construction

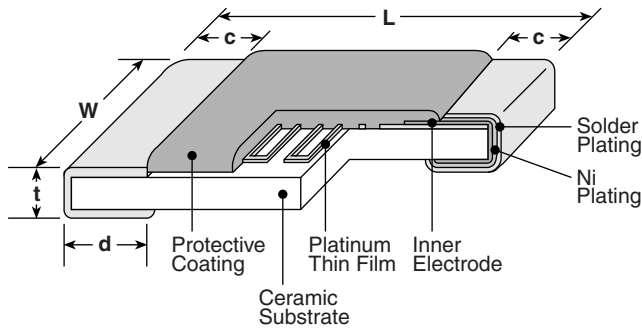

Type (Inch Size Code)	Dimensions inches (mm)				
	L	W	c	d	t
2B (1206)	.126±.008 (3.2±0.2)	.063±.008 (1.6±0.2)	.02±.012 (0.5±0.3)	.02±.012 (0.5±0.3)	.02±.006 (0.5±0.15)

thermal sensors

ordering information

SDT73H	2B	T	TE	100	F	385
Type	Size Code	Termination Material	Packaging	Nominal Resistance	Resistance Tolerance	T.C.R. (x 10⁻⁶/K)
SDT73H 2B SDT73S 2B	2B: 1206	T: Sn	TEK: 4mm pitch plastic embossed (1,000 pieces/reel) TE: 4mm pitch plastic embossed (5,000 pieces/reel)	100: 100Ω 500: 500Ω SDT73S: 100Ω	C: ±0.2% F: ±1% SDT73S: F: ±1%	385: +3850

applications and ratings

Part Designation	Resistance @ 0°C	Resistor Tolerance	Thermal Time Constant ¹	Thermal Dissipation Constant ¹	T.C.R. (ppm/°C) ²	T.C.R. Tolerance (ppm/°C)	Specified Current ⁴	Operating Temperature Range
SDT73H 2B	100Ω 500Ω	C: ±0.2% F: ±1%	6.5 seconds	2.4mW/°C	3850	±50	1mA Max.: 100Ω	-55°C to +155°C
SDT73S 2B	100Ω	F: ±1%					0.1mA Max.: 500Ω	

¹ Thermal time constant and thermal dissipation constant are reference values, which are values of elements and vary with connecting or fixing methods. Thermal dissipation constant is approx. 4mW/°C under the surface mounting condition.

² T.C.R. Measuring Temperature: 0°C/+100°C

³ When always using a SDT73S, 200°C or less is recommended.

⁴ The electricity which it is charged with in the element is moved to the range that rise in temperature due to a self-heat generation can be ignored. Ordinarily recommended measuring currents are 1mA for 100Ω and 0.1mA for 500Ω.

For further information on packaging, please refer to Appendix A.

Specifications given herein may be changed at any time without prior notice. Please confirm technical specifications before you order and/or use.

11/03/23

environmental applications

Temperature Characteristics

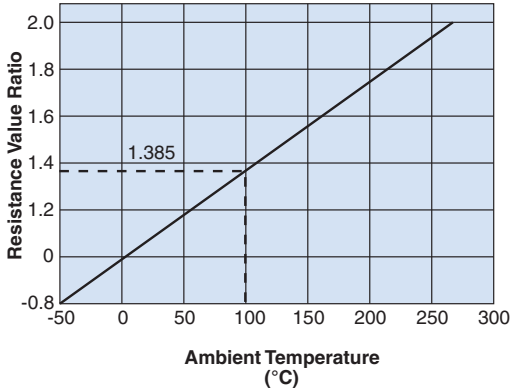

Approximate Expression for Resistance-Temperature Characteristics
 -55°C~0°C : $R_T = R_0 (1 + C_1 T + C_2 T^2 + C_3 (T-100) T^3)$
 0°C~+250°C : $R_T = R_0 (1 + C_1 T + C_2 T^2)$

R_T : Resistance value at T°C
 R_0 : Resistance value at 0°C
 T : Ambient temperature(°C)
 Constants C_1, C_2, C_3 :
 $C_1 = 3.9083 \times 10^{-3} \text{ } ^\circ\text{C}^{-1}$
 $C_2 = -5.775 \times 10^{-7} \text{ } ^\circ\text{C}^{-2}$
 $C_3 = -4.183 \times 10^{-12} \text{ } ^\circ\text{C}^{-4}$

Pt100 Resistance - Temperature Characteristics (JIS C 1604⁻¹⁹⁹⁷)

Temperature (°C)	0	-1	-2	-3	-4	-5	-6	-7	-8	-9
-50	80.31	79.91	79.51	79.11	78.72	78.32	—	—	—	—
-40	84.27	83.87	83.48	83.08	82.69	82.29	81.89	81.50	81.10	80.70
-30	88.22	87.83	87.43	87.04	86.64	86.25	85.85	85.46	85.06	84.67
-20	92.16	91.77	91.37	90.98	90.59	90.19	89.80	89.40	89.01	88.62
-10	96.09	95.69	95.30	94.91	94.52	94.12	93.73	93.34	92.95	92.55
0	100.00	99.61	99.22	98.83	98.44	98.04	97.65	97.26	96.87	96.48
	0	1	2	3	4	5	6	7	8	9
0	100.00	100.39	100.78	101.17	101.56	101.95	102.34	102.73	103.12	103.51
10	103.90	104.29	104.68	105.07	105.46	105.85	106.24	106.63	107.02	107.40
20	107.79	108.18	108.57	108.96	109.35	109.73	110.12	110.51	110.90	111.29
30	111.67	112.06	112.45	112.83	113.22	113.61	114.00	114.38	114.77	115.15
40	115.54	115.93	116.31	116.70	117.08	117.47	117.86	118.24	118.63	119.01
50	119.40	119.78	120.17	120.55	120.94	121.32	121.71	122.09	122.47	122.86
60	123.24	123.63	124.01	124.39	124.78	125.16	125.54	125.93	126.31	126.69
70	127.08	127.46	127.84	128.22	128.61	128.99	129.37	129.75	130.13	130.52
80	130.90	131.28	131.66	132.04	132.42	132.80	133.18	133.57	133.95	134.33
90	134.71	135.09	135.47	135.85	136.23	136.61	136.99	137.37	137.75	138.13
100	138.51	138.88	139.26	139.64	140.02	140.40	140.78	141.16	141.54	141.91
110	142.29	142.67	143.05	143.43	143.80	144.18	144.56	144.94	145.31	145.69
120	146.07	146.44	146.82	147.20	147.57	147.95	148.33	148.70	149.08	149.46
130	149.83	150.21	150.58	150.96	151.33	151.71	152.08	152.46	152.83	153.21
140	153.58	153.96	154.33	154.71	155.08	155.46	155.83	156.20	156.58	156.95
150	157.33	157.70	158.07	158.45	158.82	159.19	159.56	159.94	160.31	160.68
160	161.05	161.43	161.80	162.17	162.54	162.91	163.29	163.66	164.03	164.40
170	164.77	165.14	165.51	165.89	166.26	166.63	167.00	167.37	167.74	168.11
180	168.48	168.85	169.22	169.59	169.96	170.33	170.70	171.07	171.43	171.80
190	172.17	172.54	172.91	173.28	173.65	174.02	174.38	174.75	175.12	175.49
200	175.86	176.22	176.59	176.96	177.33	177.69	178.06	178.43	178.79	179.16
210	179.53	179.89	180.26	180.63	180.99	181.36	181.72	182.09	182.46	182.82
220	183.19	183.55	183.92	184.28	184.65	185.01	185.38	185.74	186.11	186.47
230	186.84	187.20	187.56	187.93	188.29	188.66	189.02	189.38	189.75	190.11
240	190.47	190.84	191.20	191.56	191.92	192.29	192.65	193.01	193.37	193.74
250	194.10	—	—	—	—	—	—	—	—	—

Note: Desired temperature values are obtained by adding temperatures in the vertical and horizontal axes. When calculating a resistance value of 105°C, read the value in the column where 100°C in the vertical axis and 5°C in the horizontal axis cross. The value will be 140.40Ω. The value for 500Ω at 0°C will be the value obtained by multiplying the resistance value in this table by 5.

Performance Characteristics

Parameter	Requirement $\Delta R \pm (\%+0.05\Omega)$		Test Method
	Limit	Typical	
Resistance	Within specified tolerance	—	0°C
T.C.R.	3850±50ppm/°C	—	0°C/ +100°C
Insulation Resistance	100MΩ or more	—	d.c. 100V
Dielectric Withstanding Voltage	±0.5%	-0.019%	a.c. 100V, 60 seconds - 70 seconds
Resistance to Solder Heat	±0.5%	-0.004%	260°C for 10 seconds
Rapid Change of Temperature	±0.5%	-0.033% (SDT73H) -0.048% (SDT73S)	-55°C (30 minutes)/ +25°C (2 - 3 minutes)/ +155°C (30 minutes) (SDT73H, SDT73S)/ +25°C (2 - 3 minutes) (SDT73S), 10 cycles
Moisture Resistance	±0.5%	-0.016%	40°C, 90 - 95% RH, 1000 hours, 1mA, 1.5 hr ON, 0.5 hr OFF cycle
Normal Temperature Load Life	±0.5%	-0.010%	20°C ± 10°C, 1000 hours, 1mA continuous turning on electricity
High Temperature Load Life	±0.5%	-0.017% (SDT73H) -0.020% (SDT73S)	+155°C, 1000 hours (SDT73H), +250°C, 1000 hours (SDT73S) 1mA continuous turning on electricity
High Temperature Exposure	±0.5%	-0.022% (SDT73H) -0.023% (SDT73S)	+155°C, 1000 hours (SDT73H), +250°C, 1000 hours (SDT73S)
Low Temperature Exposure	±0.5%	-0.029%	-55°C, 1000 hours