

axial tapings

Straight Type Name	Taping Type Name	Lead ød (mm)	Packaging Style	Packaging & Q'ty (pcs)		Weight (g)		
				AMMO	Reel	AMMO	Reel	Net 1000pcs
MOS1/2 ¹	MOS1/2CT26	0.6	T26	2000	—	350	—	140
MOS1/2	MOS1/2CT52	0.6	T52	2000	5000	590	1400	250
MOS1	MOS1CT52	0.6	T52	2000	4000	810	1550	350
MOS1	MOS1CT526	0.6	T52	2000	4000	810	1550	350
MOS1C8	MOS1CT528	0.8	T52	2000	4000	810	1550	350
MOS1	MOS1CL52	0.8	L52	2000	4000	810	1550	350
MOS2	MOS2CT52	0.8	T52	1000	2000	910	1750	800
MOS2	MOS2CT521	0.8	T521	1000	1000	910	950	800
MOS2	MOS2CL521	0.8	L521	1000	1000	910	950	800
MOS3	MOS3CL521	0.8	L521	500	—	775	—	1350
MOS3	MOS3CT521	0.8	T521	500	1000	775	1500	1350
MOS3	MOS3CT631	0.8	T631	1000	1000	1580	1600	1400
MOS3	MOS3CL631	0.8	L631	500	1000	775	1600	1400
SPR1/4 ²	SPR1/4CT26	0.45	T26	2000	—	250	—	90
SPR1/4	SPR1/4CT52	0.45	T52	2000	5000	340	850	140
SPR1/2	SPR1/2CT26	0.6	T26	2000	—	350	—	140
SPR1/2	SPR1/2CT52	0.6	T52	2000	5000	590	1400	250
SPR1/2	SPR1/2CL52	0.65	L52	2000	5000	590	1400	250
SPR1	SPR1CT52	0.8	T52	2000	4000	1140	2150	500
SPR1	SPR1CL52	0.8	L52	2000	4000	1140	2150	500
SPR2	SPR2CT52	0.8	T52	1000	2000	910	1750	800
SPR2	SPR2CT521	0.8	T521	1000	1000	910	950	800
SPR2	SPR2CL521	0.8	L521	1000	1000	910	950	800
SPR3	SPR3CT521	0.8	T521	500	1000	775	1500	1350
SPR3	SPR3CL521	0.8	L521	500	—	775	—	1350
SPR3	SPR3CT631	0.8	T631	1000	1000	1580	1600	1400
SPR3	SPR3CL631	0.8	L631	500	1000	775	1600	1400
RF16	RF16CT26	0.45	T26	2000	—	220	—	90
RF16	RF16CT52	0.45	T52	2000	5000	340	800	150
RF25	RF25CT26	0.6	T26	2000	—	330	—	140
RF25	RF25CT52	0.6	T52	2000	5000	500	1300	230
RF50	RF50CT52	0.6	T52	2000	4000	660	1320	310
RF1	RF1CT52	0.8	T52	2000	4000	1080	2050	500
RF2	RF2CT521	0.8	T521	500	1000	700	1420	1300
RF2	RF2CT631	0.8	T631	1000	—	1410	—	1350
Z16	Z16CT26	0.45	T26	5000	—	615	—	110
Z16	Z16CT52	0.45	T52	3000	5000	530	920	150
Z25	Z25CT26	0.6	T26	2000	—	410	—	180
Z25	Z25CT52	0.6	T52	2000	5000	530	1400	240
J1/6Z	J1/6ZCT26	0.5	T26	2000	—	230	—	90
J1/6Z	J1/6ZCT52	0.5	T52	2000	5000	320	950	130
J1/4Z	J1/4ZCT26	0.6	T26	2000	—	320	—	130
J1/4Z	J1/4ZCT52	0.6	T52	2000	5000	460	1310	190
JL5	JL5CT26	0.5	T26	5000	—	420	—	75
JL5	JL5CT52	0.5	T52	5000	—	680	—	120
JL6	JL6CT26	0.6	T26	5000	—	515	—	100
JL6	JL6CT52	0.6	T52	5000	—	815	—	160
JL8	JL8CT52	0.8	T52	—	10000	—	3054	305
LP1/8	LP1/8CT26	0.65	T26	2000	—	410	—	170
LP1/8	LP1/8CT52	0.65	T52	2000	—	580	—	260
LP1/16	LP1/16CT26	0.5	T26	4000	—	450	—	100
LP1/16	LP1/16CT52	0.5	T52	4000	—	630	—	150
SDT101A	SDT101AXCT26	0.4	T26	2000	—	350	—	75
SDT101A	SDT101AXCT52	0.4	T52	2000	—	470	—	150
SDT101B	SDT101BXNT52	0.4	T52	—	2000	—	410	150
CFS1/4	CFS1/4 CT26	0.45	T26	5000	—	615	—	110
CFS1/4	CFS1/4 CT52	0.45	T52	3000	5000	530	920	150
CF1/4	CF1/4 CT26	0.6	T26	2000	—	410	—	180
CF1/4	CF1/4 CT52	0.6	T52	2000	5000	530	1400	240
CFB1/2	CFB1/2 CT52	0.7	T52	2000	4000	1110	2280	520
CFS1/2	CFS1/2 CT26	0.6	T26	2000	—	525	—	230
CFS1/2	CFS1/2 CT52	0.6	T52	2000	4000	640	1500	290
CFPS1/4	CFPS1/4 CT26	0.45	T26	5000	—	615	—	100
CFPS1/4	CFPS1/4 CT52	0.45	T52	3000	—	530	—	150
CFP1/4	CFP1/4 CT26	0.6	T26	2000	—	410	—	180
CFP1/4	CFP1/4 CT52	0.6	T52	2000	5000	530	1400	240

Packaging

(1) AMMO Pack
(Symbol:A) Standard

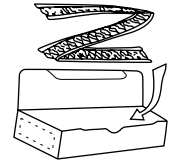

(2) Reel (Symbol: R)

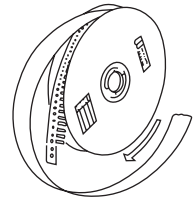

*1: The same taping applicable also to MOSX.

*2: The same taping applicable also to SPRX.

Specifications given herein may be changed at any time without prior notice. Please confirm technical specifications before you order and/or use. 11/10/23

axial tapings

Straight Type Name	Taping Type Name	Lead ød (mm)	Packaging Style	Packaging & Q'ty (pcs)		Weight (g)		
				AMMO	Reel	AMMO	Reel	Net 1000pcs
CFP1/4	CFP1/4 CL52	0.65	L52	2000	—	530	—	240
CFPB1/2	CFPB1/2 CT52	0.7	T52	2000	4000	1110	2280	520
CFPB1/2	CFPB1/2 CL52	0.65	L52	2000	—	1110	—	520
CFPS1/2	CFPS1/2 CT26	0.6	T26	2000	—	525	—	230
CFPS1/2	CFPS1/2 CT52	0.6	T52	2000	4000	640	1500	290
MFS1/4**	MFS1/4 □CT26	0.45	T26	3000	—	350	—	90
MFS1/4	MFS1/4 □CT52	0.45	T52	3000	—	500	—	120
MFS1/2	MFS1/2 □CT26	0.6	T26	2000	—	360	—	160
MFS1/2	MFS1/2 □CT52	0.6	T52	2000	5000	500	1300	215
MF1/4	MF1/4 □CT26	0.6	T26	2000	—	360	—	160
MF1/4	MF1/4 □CT52	0.6	T52	2000	5000	500	1300	215
MF1/2	MF1/2 □CT52	0.6	T52	2000	4000	900	2000	360
SNF 2C	SNF 2CCT26	0.45	T26	3000	—	500	—	110
SNF 2C	SNF 2CCT52	0.45	T52	3000	—	430	—	150
SNF 2E	SNF 2ECT26	0.6	T26	2000	—	450	—	180
SNF 2E	SNF 2ECT52	0.6	T52	2000	5000	470	1400	240
SNF 2H	SNF 2HCT52	0.7	T52	2000	4000	950	2010	520
RNS1/4	RNS1/4 □CT52	0.6	T52	2000	4000	600	1550	440
RNS1/8	RNS1/8 □CT26	0.6	T26	2000	—	400	—	180
RNS1/8	RNS1/8 □CT52	0.6	T52	2000	5000	600	1550	260
RNS1/2	RNS1/2 □CT52	0.6	T52	2000	4000	1100	2150	500
RNS1	RNS1 □CT521	0.8	T521	500	1000	750	2100	1500
RCR16	RCR16 CT26	0.45	T26	5000	—	500	—	100
RCR16	RCR16 CT52	0.45	T52	3000	—	450	—	150
RCR25	RCR25 CT26	0.6	T26	2000	—	390	—	180
RCR25	RCR25 CT52	0.6	T52	2000	—	520	—	240
RCR25EN	RCR25EN CT26	0.6	T26	2000	—	390	—	180
RCR25RN	RCR25EN CT52	0.6	T52	2000	—	520	—	240
RCR50 (+)	RCR50(+) CT52	0.7	T52	2000	3000	1050	1630	520
RCR50EN	RCR50ENCT52	0.7	T52	2000	3000	1050	1630	520
RCR60	RCR60 CT52	0.7	T52	2000	3000	1050	1630	520
RCR75	RCR75 CT52	0.8	T52	1000	—	830	—	800
RCR100	RCR100 CT521	0.8	T521	500	—	750	—	1400
RCR100	RCR100 CT631	0.8	T631	1000	—	1450	—	1400
RK1/4	RK1/4 □CT26	0.6	T26	2000	—	360	—	250
RK1/4	RK1/4 □CT52	0.6	T52	2000	5000	500	1300	250
RK1/2	RK1/2 □CT52	0.6	T52	2000	4000	900	—	380
RK1	RK1 □CT521	0.8	T521	500	—	700	—	1340
PCF1/2	PCF1/2 CT52	0.7	T52	—	2000	—	1140	450
PCF1	PCF1 CT631	0.8	T631	—	1000	—	1530	1270
PCF2	PCF2 CT631	0.8	T631	—	500	—	1340	2160
HPC1/2	HPC1/2 CT52	0.8	T52	1000	2000	800	1440	600
HPC1	HPC1 CT631	0.8	T631	—	1000	—	1440	1170
CW1/4	CW1/4 CT26	0.45	T26	2000	—	460	—	150
CW1/4	CW1/4 CT52	0.45	T52	3000	—	690	—	150
CW1/2	CW1/2 CT52	0.6	T52	2000	—	570	—	250
CW1 ⁴	CW1 CT52	0.8	T52	1000	—	580	—	650
CW2 ⁴	CW2 CT52	0.8	T52	1000	—	780	—	950
CW2 ⁴	CW2 CT521	0.8	T521	1000	—	790	—	950
CW3 ⁴	CW3 CT521	0.8	T521	500	—	740	—	1780
CW3 ⁴	CW3 CT631	0.8	T631	500	—	750	—	1780
CW1S	CW1S CT52	0.6	T52	2000	—	570	—	250
CWFS23	CWFS23 CT52	0.8	T52	1000	—	780	—	950
CWFS23	CWFS23 CT521	0.8	T521	1000	—	790	—	950
CWFS35	CWFS35 CT521	0.8	T521	500	—	740	—	1780

Packaging

(1) AMMO Pack (Symbol:A) Standard

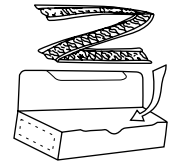

(2) Reel (Symbol: R)

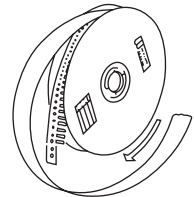

T-Type

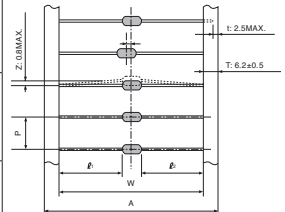

L-Type

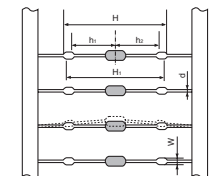

□ T.C.R. * 4 The same taping applicable also to CW-P, CW-X and CW-H
** ±0.1% and ±0.25% not available in reel packaging

T-Type

Packaging Style	Dimensions (mm)				
	W	P	A	$ l_1 - l_2 $	Accumulated Tolerance
T26 ⁶	26 ^{+0.2} ₋₀	5.00±0.3	39±1.0	0.2Max. ⁵	250.0±3mm/P×50
	26 ⁺¹ ₋₀	5.00±0.3	39±1.0	1.0Max.	100.0±2mm/P×20
T52 ⁶	52±1	5.08±0.38	64.5±1.0	1.0Max.	101.6±2mm/P×20
T521	52±1	10.16±0.80	64.5±1.0	1.0Max.	203.2±3mm/P×20
T631	63±1	10.16±0.80	—	1.0Max.	203.2±3mm/P×20

⁵ Applied to CFS1/4 (CFPS1/4) T26 Only

⁶ Contact us for LP and SDT series

Specifications given herein may be changed at any time without prior notice. Please confirm technical specifications before you order and/or use.

11/10/23

L-Type

Type	Dimensions (mm)			
	H±1	W	d	h_1, h_2
MOS ²	1 □L52	1.20~1.45	0.8	h ₁ -h ₂ ≤1
	2 □L521			
	3 □L631			
SPR ³	1/2 □L52	1.17~1.40	0.65	h ₁ -h ₂ ≤1
	1 □L52			
	2 □L521			
CFP	1/4 □L52	1.17~1.4	0.65	h ₁ -h ₂ ≤1
	1/2 □L52			
CW	1/2 □L52	26.0	1.05~1.35	0.6
CW	1 □L52	27.5	1.20~1.40	0.8

radial tapings

(mm)

VT					VT					VTE				
Radial Type Name	Radial Lead ød	AMMO (pcs)	Reel (pcs)	Weight g/AMMO	Radial Type Name	Radial Lead ød	AMMO (pcs)	Reel (pcs)	Weight g/AMMO	Radial Type Name	Radial Lead ød	AMMO (pcs)	Reel (pcs)	Weight g/AMMO
MFS1/2 CVT	0.6	2000	2500	750	MFS1/4 CVT	0.45	3000	3000	620	MFS1/2 CVTE	0.6	2000	2500	750
MF1/4 CVT	0.6	2000	2500	750	CFS1/4 CVT	0.45	3000	3000	720	MF1/4 CVTE	0.6	2000	2500	750
RNS1/8 CVT	0.6	2000	2500	750	SPR1/4 CVT*	0.45	3000	3000	720	RNS1/8 CVTE	0.6	2000	2500	750
J1/4Z CVT*	0.6	2000	2500	670						MOS1/2 CVTE	0.6	2500	2500	930
CF1/4 CVT	0.6	2000	2500	720						SPR1/2 CVTE	0.6	2500	2500	930
CFS1/2 CVT	0.6	2000	2500	800						CF1/4 CVTE	0.6	2500	2500	900
CFP1/4 CVT*	0.6	2000	2500	720						CFS1/2 CVTE	0.6	2500	2500	1000
CFPS1/2 CVT*	0.6	2000	2500	800						RF25 CVTE	0.6	2000	2500	750
RF25 CVT*	0.6	2000	2500	750										
VTP					VTF									
Radial Type Name	Radial Lead ød	AMMO (pcs)	Reel (pcs)	Weight g/AMMO	Radial Type Name	Radial Lead ød	AMMO (pcs)	Reel (pcs)	Weight g/AMMO	Radial Type Name	Radial Lead ød	AMMO (pcs)	Reel (pcs)	Weight g/AMMO
CW1/2 CVTP*	0.6	2000	—	750	J1/4Z CVTP*	0.6	2000	2500	670	SPR2CVTF	0.8	1000	—	1080
CW1 CVTP*	0.8	1000	—	740	MF1/4 CVTP	0.6	2000	2500	750	MOS2CVTF	0.8	1000	—	1060
CW2 CVTP*	0.8	1000	—	1080	RNS1/8 CVTP	0.6	2000	2500	750					
					CF1/4 CVTP	0.6	2000	2500	740					
					CFS1/2 CVTP	0.6	2000	2500	800					
					CFP1/4 CVTP	0.6	2000	2500	740					
					CFPS1/2 CVTP	0.6	2000	2500	800					
					RF25 CVTP	0.6	2000	2500	750					
					RCR75 CVTP**	0.65	1000	—	1080					
MT					MHT					FT				
Radial Type Name	Radial Lead ød	AMMO (pcs)	Reel (pcs)	Weight g/AMMO	Radial Type Name	Radial Lead ød	AMMO (pcs)	Reel (pcs)	Weight g/AMMO	Radial Type Name	Radial Lead ød	AMMO (pcs)	Reel (pcs)	Weight g/AMMO
MFS1/4 CMT	0.45	3000	—	620	CFS1/4 CMHT	0.45	3000	—	630	BPR26 CFT	0.6	500	—	790
CFS1/4 CMT	0.45	3000	3000	630	CFPS1/4 CMHT	0.6	3000	—	720	BPR58 CFT	0.8	500	—	1940
CFPS1/4 CMT	0.45	3000	3000	630	RF16 CMHT	0.45	3000	—	240					
J1/6Z CMT	0.5	2000	—	450										

□ T.C.R. * The insulated coating on the lead wire is not available.
 Also for MOSX, SPRX types, radial taping in the same shape as MOS, SPR types is applicable.
 ** Surge resistance is not guaranteed. Rating specifications are different. Please contact KOA for details.

Specifications given herein may be changed at any time without prior notice. Please confirm technical specifications before you order and/or use. 11/30/22

radial tapings



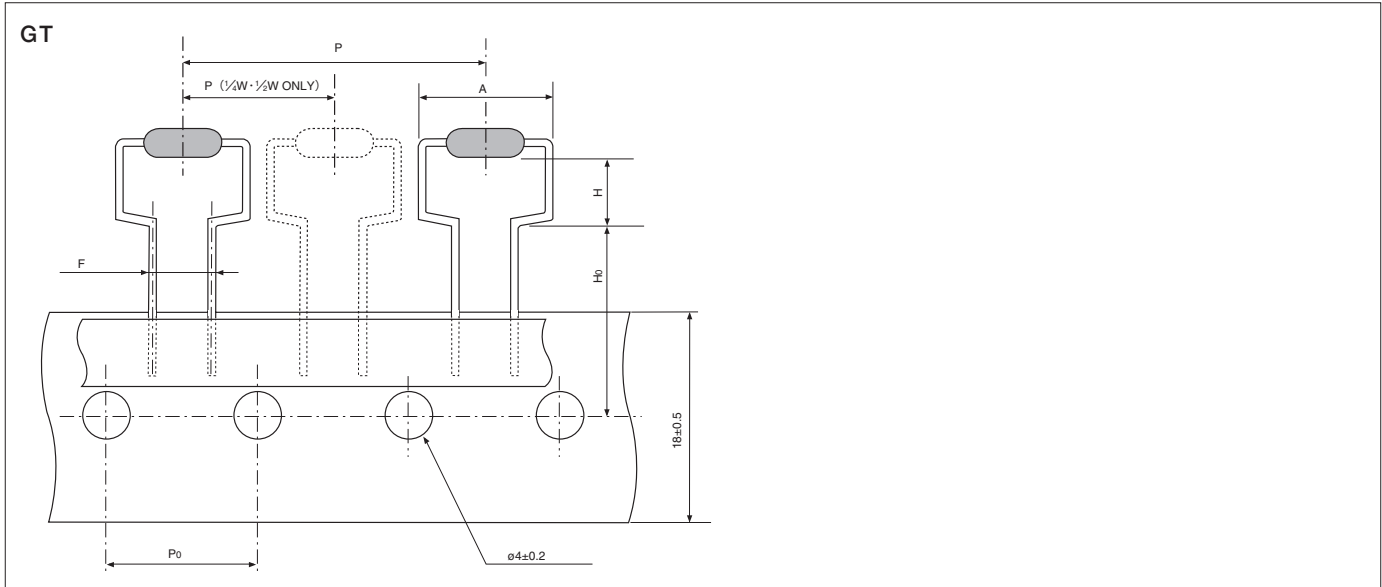

(mm)

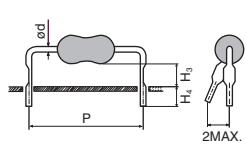

Radial Type Name	Radial Lead ød	AMMO (pcs)	Weight g/AMMO	F	P	P0	H	H0	AMax.
MOS1/2CGT	0.6	2000	740	5±0.5	12.7±1.0	12.7±0.3	6.5 ^{+0.6} ₋₀	16±0.5	12
MOS1CGT	0.8	1000	730	7.5 ^{+0.8} _{-0.2}	30±1.0	15±0.3	6.5 ^{+1.0} ₋₀	19±0.7	14.5
MOS1CGT4	0.8	1000	700				4.0 ^{+1.0} ₋₀		17.5
MOS2CGT	0.8	500	580				7.5 ^{+1.0} ₋₀		21
MOS2CGT4	0.8	500	560				4.0 ^{+1.0} ₋₀		
MOS3CGT	0.8	500	910				8.5 ^{+1.0} ₋₀		
MOS3CGTS ¹	0.8	500	910	7.5±0.5			5.5±1.0	19±1.0	21
SPR1/2CGT	0.6	2000	740	5±0.5	12.7±1.0	12.7±0.3	6.5 ^{+0.6} ₋₀	16±0.5	12
SPR1CGT	0.8	1000	770	7.5 ^{+0.8} _{-0.2}	30±1.0	15±0.3	6.5 ^{+1.0} ₋₀	19±0.7	14.5
SPR2CGT	0.8	500	540				7.5 ^{+1.0} ₋₀		17.5
SPR3CGT	0.8	500	910				8.5 ^{+1.0} ₋₀		
CFP1/4CGT	0.65	2000	720	5±0.5	12.7±1.0	12.7±0.3	6.5 ^{+0.6} ₋₀	16±0.5	12
CFPS1/2CGT	0.8	1500	600	5±0.5	12.7±1.0	12.7±0.3	6.5 ^{+0.6} ₋₀	16±0.5	12
CW1HCGT	0.8	1000	920	7.5 ^{+0.8} _{-0.2}	30±1.0	15±0.3	6.5 ^{+1.0} ₋₀	19±0.7	14.5
RF50CGT	0.8	1000	730						
RF1CGT	0.8	1000	770				8.5 ^{+1.0} ₋₀		21
RF2CGT	0.8	500	1820						
CW2CGT	0.8	500	1080						
CW3CGT	0.8	500	1820				8.5 ^{+1.0} ₋₀		21

□ T.C.R.
 Also for MOSX, SPRX types, radial taping in the same shape as MOS, SPR types is applicable.

forming (not available taping)

Forming Style	Forming Type Name	Forming Dimension (mm)				Weight g/100pcs	Basic Unit (pcs)	Straight Type Name
		P±1	H3±1orH5	H4±1orH6	d			
L Forming 	CW1/2CL10A (CW1SCL10A)	10.0	5.3	4.5	0.6	24	2000	CW1/2 (CW1S)
	CW1CL12.5A (CW1PCL12.5A) (CW1HCL12.5A)	12.5	6.5	4.0	0.8	56	1000	CW1 (CW1P) (CW1H)
	CW1CL15A (CW1PCL15A) (CW1HCL15A)	15.0	5.3	4.5	0.8	56	1000	CW1 (CW1P) (CW1H)
	CW2CL15A (CW2PCL15A) (CW2HCL15A)	15.0	7.0	4.5	0.8	84	1000	CW2 (CW2P) (CW2H)
	CW2CL20A (CW2PCL20A) (CW2HCL20A)	20.0	8.0	4.5	0.8	84	1000	CW2 (CW2P) (CW2H)
	CW3CL20A (CW3PCL20A) (CW3HCL20A)	20.0	8.0	4.0	0.8	160	1000	CW3 (CW3P) (CW3H)
	CW3CL25A (CW3PCL25A) (CW3HCL25A)	25.0	7.0	4.5	0.8	160	1000	CW3 (CW3P) (CW3H)
	CW5CL30A	30.0	8.5	4.5	0.8	524	500	CW5
	CW5CL35A	35.0	5.5	4.5	0.8	524	500	CW5
	MOS1/2CL10A (MOSX1/2CL10A)	10.0	5.3±1.0	4.0±1.0	0.6	23	2000	MOS1/2 (MOSX1/2)
	MOS1CL12.5A (MOSX1CL12.5A)	12.5	7.0±1.0	4.0±1.0	0.8	31	2000	MOS1 (MOSX1)
	MOS1CL15A (MOSX1CL15A)	15.0	6.5±1.0	4.0±1.0	0.8	31	2000	MOS1 (MOSX1)
	MOS2CL15A (MOSX2CL15A)	15.0	7.0±1.0	4.0±1.0	0.8	71	2000	MOS2 (MOSX2)
	MOS2CL15F (MOSX2CL15F)	15.0	4.5±1.0	4.0±1.0	0.8	71	2000	MOS2 (MOSX2)
	MOS2CL20A (MOSX2CL20A)	20.0	9.0±1.0	4.0±1.0	0.8	71	2000	MOS2 (MOSX2)
	MOS2CL20D (MOSX2CL20D)	20.0	4.8±1.0	4.0±1.0	0.8	71	2000	MOS2 (MOSX2)
	MOS3CL20A (MOSX3CL20A)	20.0	8.0±1.0	4.0±1.0	0.8	130	1000	MOS3 (MOSX3)
	MOS3CL20C (MOSX3CL20C)	20.0	10.0±1.0	4.0±1.0	0.8	130	1000	MOS3 (MOSX3)
	MOS3CL20T (MOSX3CL20T)	20.0	4.0±1.0	4.0±1.0	0.8	130	1000	MOS3 (MOSX3)
	MOS3CL25A (MOSX3CL25A)	25.0	7.0±1.0	4.0±1.0	0.8	130	1000	MOS3 (MOSX3)
	MOS3CL30A (MOSX3CL30A)	30.0	7.0±1.0	4.0±1.0	0.8	130	1000	MOS3 (MOSX3)
	MOS5CL30A (MOSX5CL30A)	30.0	8.5±1.0	4.0±1.0	0.8	524	500	MOS5 (MOSX5)
	MOS5CL35A (MOSX5CL35A)	35.0	5.5±1.0	4.0±1.0	0.8	524	500	MOS5 (MOSX5)
	SPR1/2CL10A (SPRX1/2CL10A)	10.0	5.3	4.0	0.6	23	2000	SPR1/2 (SPRX1/2)
	SPR1CL12.5A (SPRX1CL12.5A)	12.5	6.5	4.0	0.8	54	2000	SPR1 (SPRX1)
	SPR1CL15A (SPRX1CL15A)	15.0	5.3	4.0	0.8	54	2000	SPR1 (SPRX1)
	SPR2CL15A (SPRX2CL15A)	15.0	7.0	4.0	0.8	71	2000	SPR2 (SPRX2)
	SPR2CL20A (SPRX2CL20A)	20.0	9.0	4.0	0.8	71	2000	SPR2 (SPRX2)
	SPR3CL20A (SPRX3CL20A)	20.0	8.0	4.0	0.8	141	1000	SPR3 (SPRX3)
	SPR3CL25A (SPRX3CL25A)	25.0	7.0	4.0	0.8	141	1000	SPR3 (SPRX3)
	SPR5CL30A (SPRX5CL30A)	30.0	8.5	4.0	0.8	456	500	SPR5 (SPRX5)
	SPR5CL35A (SPRX5CL35A)	35.0	5.5	4.0	0.8	456	500	SPR5 (SPRX5)
	RCR50(+)CL15A	15.0	5.3	4.5	0.7	34	2000	RCR50 (+)
	RCR50ENCL15A	15.0	5.3	4.5	0.7	34	2000	RCR50EN
	RCR60CL15A	15.0	5.3	4.5	0.7	34	2000	RCR60
	RCR75CL15A	15.0	7.0	4.5	0.8	69	2000	RCR75
	RCR100CL20A	20.0	8.0	4.0	0.8	142	1000	RCR100
	RCR100CL25A	25.0	7.0	4.0	0.8	142	1000	RCR100
	RK1/4□CL10A	10.0	5.3	4.5	0.6	23	1000	RK1/4
	RK1□CL20A	20.0	8.8	4.5	0.8	146	1000	RK1
	CFP1/4CL10A	10.0	6.5	4.5	0.65	23	1000	CFP1/4
	CFPB1/2CL12.5A	12.5	6.5	4.5	0.65	44	1000	CFPB1/2
	RF25CL10A	10.0	5.35	5.0	0.6	23	2000	RF25
	RF50CL12.5A	12.5	6.0	5.2	0.6	29	2000	RF50
	RF50CL15A	15.0	6.0	5.3	0.6	29	2000	RF50
	RF1CL12.5A	12.5	6.5	4.8	0.8	46	2000	RF1
	RF1CL15A	15.0	5.3	4.5	0.8	46	2000	RF1
	RF1CL20A	20.0	5.3	4.5	0.8	46	2000	RF1
RF2CL20A	20.0	8.0	5.0	0.8	141	1000	RF2	
RF2CL25A	25.0	7.0	4.5	0.8	141	1000	RF2	
U Forming 	MFS1/4□CU	-	5.5Max.	15.0±1.0	0.45	14	2000	MFS1/4
	CFS1/4CU	-	5.5Max.	15.0±1.0	0.45	12	2000	CFS1/4
U Forming 	MF1/4□CU	-	9.5Max.	28.0±3.0	0.6	23	1000	MF1/4
	RK1/4□CU	-	9.5Max.	30.0±3.0	0.6	23	1000	RK1/4
	CF1/4CUCL	-	10.0Max.	10.0±1.0	0.6	23	1000	CF1/4
U Forming 	MOS1CU (MOSX1CU)	-	21.0Max.	15.0Min.	0.8	55	1000	MOS1 (MOSX1)
	MOS2CU (MOSX2CU)	-	23.5Max.	15.0Min.	0.8	85	1000	MOS2 (MOSX2)
	MOS3CU (MOSX3CU)	-	26.0Max.	15.0Min.	0.8	150	1000	MOS3 (MOSX3)
	SPR1CU (SPRX1CU)	-	21.0Max.	15.0Min.	0.8	54	1000	SPR1 (SPRX1)
	SPR2CU (SPRX2CU)	-	23.5Max.	15.0Min.	0.8	93	1000	SPR2 (SPRX2)
	SPR3CU (SPRX3CU)	-	26.0Max.	15.0Min.	0.8	141	1000	SPR3 (SPRX3)
	UCL Forming 	MOS1CUCL (MOSX1CUCL)	-	13.0±1.0	3.5±1.0	0.8	30	1000
MOS2CUCL (MOSX2CUCL)		-	14.5±1.0	3.5±1.0	0.8	60	1000	MOS (X)2
MOS3CUCL (MOSX3CUCL)		-	20.0Max.	4.0±1.0	0.8	130	1000	MOS (X)3

□ T.C.R.

forming (not available taping)

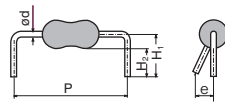
Forming Style	Forming Type Name	Forming Dimension (mm)					Weight g/100pcs	Basic Unit (pcs)	Straight Type Name
		P±1	H1	H2	e Max.	d			
M Forming 	MFS1/4□CM5F	5.0	-	5.0±1.0	2.0	0.45	14	2000	MFS1/4
	MFS1/4□CM5R	5.0	10.0±1.0	-	2.0	0.45	14	2000	MFS1/4
	MFS1/4□CM5W	5.0	-	15.0±1.0	2.0	0.45	14	1000	MFS1/4
	MFS1/2□CM10R	10.0	10.0±1.0	-	2.0	0.6	23	2000	MFS1/2
	MF1/4□CM10F	10.0	-	5.0±1.0	2.0	0.6	23	2000	MF1/4
	MF1/4□CM12.5R	12.5	10.0±1.0	-	2.0	0.6	23	2000	MF1/4
	MF1/2□CM12.5R	12.5	10.0±1.0	-	2.0	0.6	41	1000	MF1/2
	MF1/2□CM15R	15.0	10.0±1.0	-	2.0	0.6	41	1000	MF1/2
	SNF 2CCM5F	5.0	-	5.0±1.0	1.5	0.45	14	2000	SNF 2C
	SNF 2ECM10F	10.0	-	5.0±1.0	1.7	0.6	24	2000	SNF 2E
SNF 2ECM12.5R	12.5	10.0±1.0	-	1.7	0.6	24	2000	SNF 2E	
SNF 2HCM12.5K	12.5	7.0±1.0	-	2.0	0.7	41	2000	SNF 2H	
SNF 2HCM15K	15.0	7.0±1.0	-	2.0	0.7	41	2000	SNF 2H	
RCR16CM5F	5.0	-	5.0±1.0	2.0	0.45	14	2000	RCR16	
RCR25CM10F	10.0	-	5.0±1.0	2.0	0.6	23	2000	RCR25	
RCR25ENCM10F	10.0	-	5.0±1.0	2.0	0.6	23	2000	RCR25EN	
RCR50(+)CM15F	15.0	-	5.0±1.0	2.0	0.7	40	2000	RCR50	
RCR50CM15F	15.0	-	5.0±1.0	2.0	0.7	40	2000	RCR50+	
RCR60CM15F	15.0	-	5.0±1.0	2.0	0.7	40	2000	RCR60	
RCR100CM20E	20.0	-	4.6±1.0	2.0	0.8	120	1000	RCR100	
RK1/4□CM10F	10.0	-	5.0±1.0	1.7	0.6	21	1000	RK1/4	
RK1/4□CM10R	10.0	-	10.0±1.0	1.7	0.6	21	1000	RK1/4	
RK1/4□CM12.5R	12.5	-	10.0±1.0	1.7	0.6	23	1000	RK1/4	
RK1/2□CM15F	15.0	-	5.0±1.0	2.0	0.6	40	1000	RK1/2	
RK1/2□CM12.5F	12.5	-	5.0±1.0	2.0	0.6	37	1000	RK1/2	
RK1/2□CM15R	15.0	-	10.0±1.0	2.0	0.6	37	1000	RK1/2	
CFS1/4CM5F	5.0	5.9±1.0	5.0±1.0	1.5	0.45	12	2000	CFS1/4	
CF1/4CM10H	10.0	6.0±1.0	4.8±1.0	1.7	0.6	23	1000	CF1/4	
CF1/4CM12.5H	12.5	6.0±1.0	4.8±1.0	1.7	0.6	23	2000	CF1/4	
CFB1/2CM12.5K	12.5	7.0±1.0	5.0±1.0	1.7	0.7	44	1000	CFB1/2	
CFS1/2CM10H	10.0	6.0±1.0	4.8±1.0	1.7	0.6	26	1000	CFS1/2	
CFPS1/4CM5F	5.0	5.9±1.0	5.0±1.0	1.5	0.45	12	2000	CFPS1/4	
CFP1/4CM10H	10.0	6.0±1.0	4.8±1.0	1.7	0.6	23	1000	CFP1/4	
CFPB1/2CM12.5K	12.5	7.0±1.0	5.0±1.0	2.0	0.7	44	1000	CFB1/2	
J1/6ZCM7.5H	7.5	-	5.0 ^{+2.0} _{-0.0}	1.5	0.5	5	1000	J1/6Z	
J1/4ZCM10H	10.0	-	5.0 ^{+2.0} _{-0.0}	1.5	0.6	9	1000	J1/4Z	
RF16CM5F	5.0	-	5.0±1.0	2.0	0.45	12	2000	RF16	
RF25CM10X	10.0	16.0±1.0	14.8±1.0	1.5	0.6	23	2000	RF25	
RF50CM12.5E	12.5	-	4.5±1.0	1.5	0.6	29	1000	RF50	
RF1CM15F	15.0	-	5.0±1.0	1.5	0.8	46	2000	RF1	
MOS1/2CM10C (MOSX1/2CM10C)	10.0	-	3.5±1.0	2.0	0.6	23	2000	MOS (X) 1/2	
MOS1/2CM10F (MOSX1/2CM10F)	10.0	-	5.0±1.0	2.0	0.6	23	2000	MOS (X) 1/2	
MOS1CM12.5C (MOSX1CM12.5C)	12.5	-	3.5±1.0	2.0	0.8	31	2000	MOS (X) 1	
MOS1CM12.5D (MOSX1CM12.5D)	12.5	-	4.0±1.0	2.0	0.8	31	2000	MOS (X) 1	
MOS1CM15F (MOSX1CM15F)	15.0	-	5.0±1.0	2.0	0.8	31	2000	MOS (X) 1	
MOS1CM15J (MOSX1CM15J)	15.0	-	6.3±1.0	2.0	0.8	31	2000	MOS (X) 1	
MOS1CM15S (MOSX1CM15S)	15.0	-	11.0±1.0	2.0	0.8	31	2000	MOS (X) 1	
MOS2CM15C (MOSX2CM15C)	15.0	-	3.5±1.0	2.0	0.8	71	2000	MOS (X) 2	
MOS2CM15E (MOSX2CM15E)	15.0	-	4.5±1.0	2.0	0.8	71	2000	MOS (X) 2	
MOS2CM20D (MOSX2CM20D)	20.0	-	4.0±1.0	2.0	0.8	71	2000	MOS (X) 2	
MOS2CM20U (MOSX2CM20U)	20.0	-	13.5±1.5	2.0	0.8	71	2000	MOS (X) 2	
MOS3CM20E (MOSX3CM20E)	20.0	-	4.6±1.0	2.0	0.8	120	1000	MOS (X) 3	
MOS3CM26E (MOSX3CM26E)	26.0	-	4.7±1.0	2.0	0.8	120	1000	MOS (X) 3	
MOS5CM30U (MOSX5CM30U)	30.0	-	13.0±1.0	2.0	0.8	456	500	MOS (X) 5	
SPR1/2CM10F (SPRX1/2CM10F)	10.0	-	5.0±1.0	2.0	0.6	23	2000	SPR1/2	
SPR1CM12.5D (SPRX1CM12.5D)	12.5	-	4.0±1.0	2.0	0.8	44	2000	SPR1	
SPR1CM15F (SPRX1CM15F)	15.0	-	5.0±1.0	2.0	0.8	44	2000	SPR1	
SPR2CM15E (SPRX2CM15E)	15.0	-	4.5±1.0	2.0	0.8	71	2000	SPR2	
SPR3CM20E (SPRX3CM20E)	20.0	-	4.6±1.0	2.0	0.8	120	1000	SPR3	

□ T.C.R.

minimum ordered quantity

Chip Components

Type	Basic Unit/Bag	Quantity /Box	Taping
RK73B, RK73H	1F~W3A2	1,000	—
RK73G	1H~2B	1,000	—
RK73Z	1F~W3A	1,000	—
RS73	1J~2B	1,000	—
HSG73P	1E~2B	1,000	—
RN73R, RN73H	1E~2E	200	—
WK73, WU73 WG73	1E~3A3	1,000	—
WN73H	1J, 2B	200	—
SR73	1H~W3A2	1,000	—
UR73, UR73D, UR73V, UR73VH, UR73VD	1E~3A	1,000	—
HV73, HV73V	1J~3A	1,000	—
SG73, SG73P, SG73S, SG73G	1E~W3A	1,000	—
SLR	1	100	—
MWS	5	—	1,500
PSF, PSL		100	—
TLR, TLRH	1J, 2A, 2BP, 2B, 2H, 3AW, 2BW, 2HW, 3AP, 3APS	100	—
SL, SLN	07, 1, 2, W07, W1, 3, 5	100	—
TSL	1	100	—
CSR	1, 2	100	—
RD41	2ES	2,000	40,000
	2E	2,000	10,000
RN41	2ES	2,000	40,000
	3AS	2,000	10,000
CC	12M	2,000	40,000
	25	2,000	10,000
CPCN	1/2	1,000	10,000
	1, 2N, 2NS	1,000	5,000
	3	500	2,000
RF73	1J~3A	200	—
LT73, LT73V	2A, 2B	200	—
LP73	1J	1,000	—
	2A, 2B	500	—
SDT73H, SDT73S, SDT73V	2B	100	—
CNN	2A	100	—
TF	10B, 16S, 16A, 16VN	100	—
CCF	1N, 1F	100	—
NV73	1H~1E	—	—
NV73, NV73DL	1J~2B	1,000	—
NV73DS	2L	500	—
RCU		100	—
RCT		100	—
RCS		100	—
RCW		100	—

() is flat container

*1 MOQ may vary depending on the country of purchase. Please contact our sales office in charge.

*2 Please contact us for other lug terminals.

Discrete Components

Type	Basic Unit/Bag	Taping
CF (CFP)	S1/4CS, S1/4	2,000
	1/4, B1/2, S1/2, 1/4CS	1,000
MF (MFP)	S1/4	2,000
	S1/2, 1/4, 1/2	1,000
SN	3A	1,000
	3D	500
SNF	2C	2,000
	2E, 2H	1,000
RNS	1/8~1	100
RK	1/4~1	1,000
RCR	16, 25	2,000
	50, 50+, 60, 75	2,000
	100	1,000
HPC	1/2	3,000
	1	1,000
	2, 3	1,000
	4, 5	500
PCF	1/2	2,000
	1	1,000
RF	2	500
	16~1	2,000
RF25CC	2	1,000
MOS (MOSX)	1/2~2	2,000
	3, 1U, 2U	1,000
	5	500
SPR (SPRX)	1/4	2,000
	1/2~2	2,000
	3, 1U, 2U	1,000
	5	500
CW	1/2~3	1,000
	5	500
BPR **	26, 28	(1,000)
	38	(1,000)
	58	(1,000)
	108, 55, 77	(400)
LR	6~29	1,000
BGR, BWR, BSR	2N, 3N, 5N	(1500)
	7N	(700)
	10N	(600)
	5E, 5P	500
BGR, BWR, BSR (Straight type)	1	500
	2, 3	(1000)
	5	(700)
	7, 10	(500)
	15	(320)
	20	(300)
BGR, BSR (Lug terminal *)	15, 20	500
	10~20HA, 10~20QA	400
	30 (BGR)	180
	40 (BGR)	150
	30HA, 30QA	180
BWRV, BSRV	40HA, 40QA	144
	3N, 5N	(1500)
	7N	(700)
	10N	(600)

Please refer to product pages for taping quantities.

Specifications given herein may be changed at any time without prior notice. Please confirm technical specifications before you order and/or use.

11/14/23

Discrete Components (continued)

Type	Basic Unit/Bag	Taping	
BWRV, BSRV (Straight type)	3	(1000)	—
	5	(700)	—
	7, 10	(500)	—
	15	(320)	—
	20	(300)	—
BGRV, BSRV (Lug terminal ^{*2})	15, 20	500	—
	10~20QA	400	—
	30, 40	150	—
	30~40QC	20	—
	30~40QE	75	—
BWRV (Lug terminal)	40	135	—
	40QE	75	—
Z	16	2,000	O
	25	1,000	O
J1/6Z, J1/4Z	1,000	O	
JLT	—	O	

() is flat container * Please contact us for other lug terminals.

Type	Basic Unit/Bag	Quantity /Box	Taping	
GS	1/4	100	1,000 *3	
	1/2	50	2,000 *3	
	1	50	2,000	—
	2, 5, 3	10	250	—
	7, 10, 12	10	100	—
LP	1/16	100	2,000	O
	1/8	100	1,000	O
SDT101	A	100	2,000	O
	B	100	2,500	O
SDT101S	A	100	2,500	—
SDT310	HCTP,LTC,P, MTM,HLTC,AP	100	1,000	—
	VASP2B (Bulk)	100	1,000	—
	VASP2K (Tray)	200	1,000	—
PSN-PV-PSO-PN-PWW-PAP	1	—	—	
AFS	1	—	—	
RW	1/2	20	1000	—
	1	20	1000	—
	2~7	20	500	—
	10	20	300	—
CR	100	1000	—	
MRP	3 pin	100	3000	—
HS	4015	—	Box (324)	—
	4022	—	Box (216)	—
	8018	—	Box (180)	—
	8022	—	Box (120)	—

Please refer to product pages for taping quantities.

*1 Custom taping for GS1/4, GS1/2 are available on request.

surface mounted device style lead forming

Ratings

Type	Forming Type Name	Carrier Type	Forming Dimensions (mm)				Quantity/ Reel (pcs)	Weight (g)	
			P	T	A	d		Reel	NET/1000pcs
MOS (X) 1C	N14.5	TEB	14.5 ± 1	5.0 ± 0.5	4.8 ± 0.5	0.8	1000	700	350
MOS (X) 2C SPR(X) 2C RCR75C CW2C	N17	TEB	17.0 ± 1	6.0 ± 0.5	5.8 ± 0.5	0.8	1000	900	600
MOS (X) 3 SPR(X) 3 RCR100 CW3C	N20	TEG	20.0 ± 1	7.5 ± 1	6.5 ± 0.5	0.8	900	1,800	1,400

Forming Style

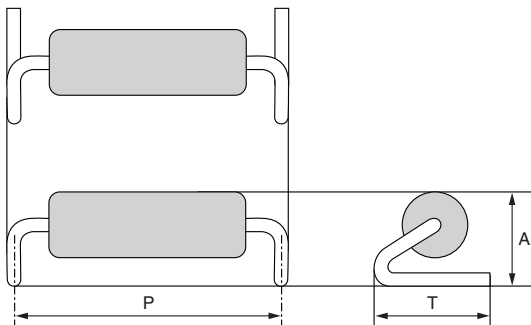

Packaging Specifications

Carrier tape: TEB (N14.5, N17)

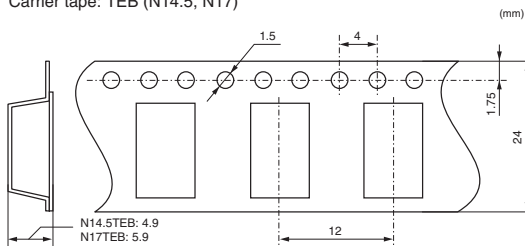

Carrier tape: TEG (N20)

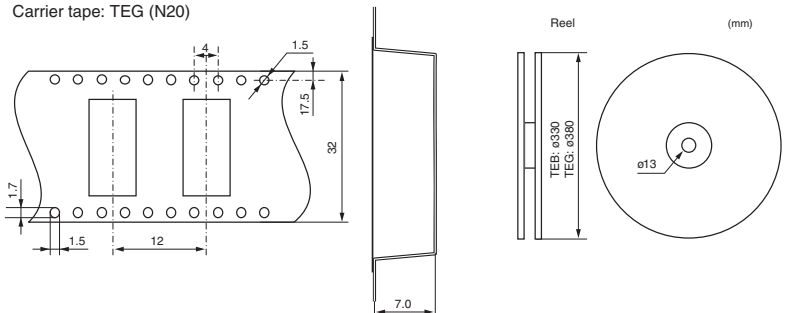

Recommended Pad Dimensions

Type	Forming Type Name	Forming Dimensions (mm)			
		A	B	C	D
MOS (X) 1C	N14.5TEB	12.5	16.5	7.0	2.0
MOS (X) 2C SPR(X) 2C RCR75C CW2C	N17TEB	14.6	19.4	8.0	2.4
MOS (X) 3 SPR(X) 3 RCR100 CW3C	N20TEG	17.6	22.4	9.5	2.4

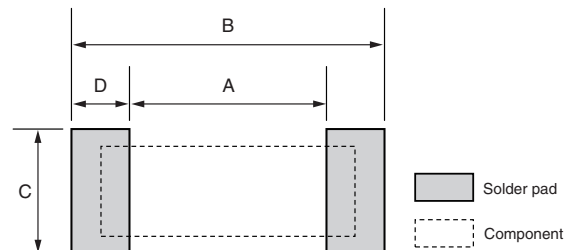

- Need a dedicated nozzle for automatic mounting. Please ask us before use.